

SECT A-A

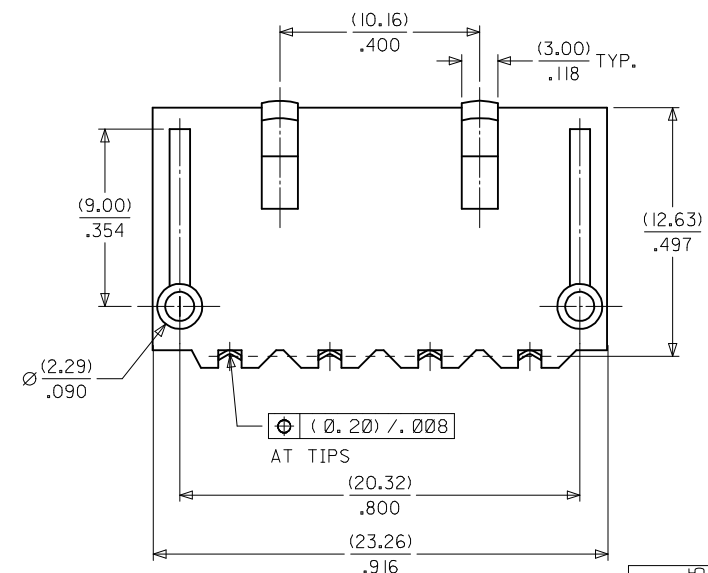

- NOTES:
- 1) MATERIAL
HOUSING - NYLON 6/6, UNFILLED, UL94V-2, COLOR: NATURAL(OFF-WHITE)
TERMINAL - PHOSPHOR BRONZE
PLATING - POSTPLATE(0.00254)/.000100 MIN.
TIN OVER (0.00127)/.000050 MIN.
NICKEL OVERALL.
 - 2) PART INTENDED TO MATE WITH HOUSING 8981-4P AND TERMINAL 8980-3*
 - 3) PRODUCT SPEC PS-8981-4V* APPLIES.
 4. PARTS TO BE PACKED IN MOISTURE BARRIER BAG.

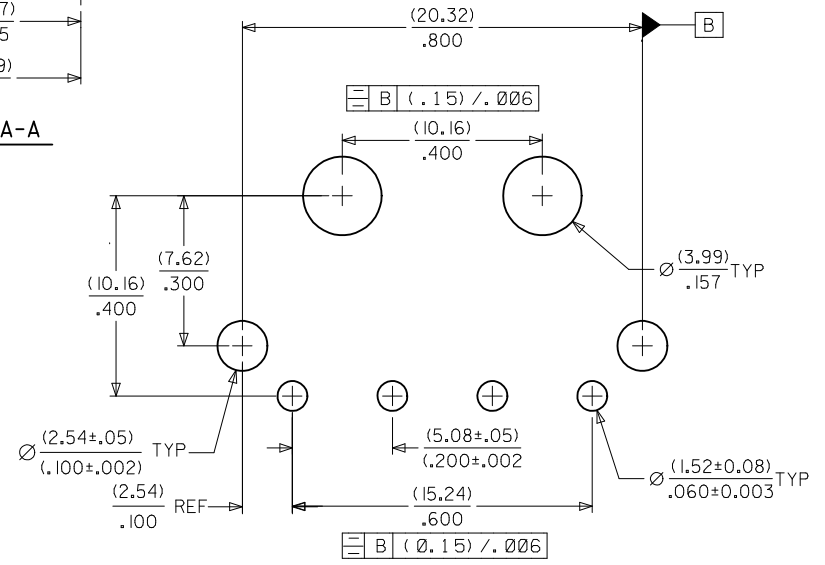

RECOMMENDED P.C. BOARD LAYOUT (TOL. +/- (.13)/.005)

| | | |
|----------------|------------|-------------|
| MAT'L NO. | ENG. NO. | 'L' |
| A-8981-4R-1-LF | 15-24-4441 | (3.56)/.140 |

| | | | | | | | | | | | | | | | | | | | | | |
|---|-------------------------------|--|------------------------------------|----------------------------|------|----------|-------|-------|----------|-------|--------|----------|--------|-------|---------|-------|-------|---------------------------------|---------------------|-----------------------------|------------------------|
| ADD DIM EC NO: S2012-0938 DRWN:SKANG CHKD:ATSEE APPR:MLONG 2012/06/15 2012/07/06 2012/07/06 | QUALITY SYMBOLS ▽=0 ◻=0 | GENERAL TOLERANCES (UNLESS SPECIFIED) <table border="1"> <tr> <td></td> <td>mm</td> <td>INCH</td> </tr> <tr> <td>4 PLACES</td> <td>± ---</td> <td>± ---</td> </tr> <tr> <td>3 PLACES</td> <td>± ---</td> <td>± .008</td> </tr> <tr> <td>2 PLACES</td> <td>± 0.20</td> <td>± ---</td> </tr> <tr> <td>1 PLACE</td> <td>± ---</td> <td>± ---</td> </tr> </table> | | mm | INCH | 4 PLACES | ± --- | ± --- | 3 PLACES | ± --- | ± .008 | 2 PLACES | ± 0.20 | ± --- | 1 PLACE | ± --- | ± --- | DIMENSION STYLE MM/IN | SCALE NTS | DESIGN UNITS INCH | THIRD ANGLE PROJECTION |
| | | mm | INCH | | | | | | | | | | | | | | | | | | |
| | 4 PLACES | ± --- | ± --- | | | | | | | | | | | | | | | | | | |
| | 3 PLACES | ± --- | ± .008 | | | | | | | | | | | | | | | | | | |
| 2 PLACES | ± 0.20 | ± --- | | | | | | | | | | | | | | | | | | | |
| 1 PLACE | ± --- | ± --- | | | | | | | | | | | | | | | | | | | |
| DRAWN BY GRXIE | DATE 2001/05/02 | TITLE HEADER, 4 CKTS RIGHT ANGLE MOUNT | | | | | | | | | | | | | | | | | | | |
| CHECKED BY KCL ING | DATE 2001/05/02 | MOLEX INCORPORATED | | | | | | | | | | | | | | | | | | | |
| APPROVED BY SKTOH | DATE 2001/05/03 | MATERIAL NO. SEE TABLE | DOCUMENT NO. SD-8981-4R1 | SHEET NO. 1 OF 1 | | | | | | | | | | | | | | | | | |